

## G\_100 – As powerful as small

Gas ring vacuum pumps and compressors

At a height of 125 mm, a width of 125 mm (4.9 in) and a depth of 60 mm (2.4 in) (about the size of a CD), these G\_100 (2BH100) gas ring blowers are the smallest on the market. They are suitable for use in many fields where space for blower operation is limited, and their unbelievably light weight (less than 1 kg/2.2 lbs.) makes them the ideal choice for mobile applications. The stepless and precise suction capacity of these machines means they always provide only the exact power that you actually need.

### Dependable and durable in continuous operation

G\_100 machines are robust powerhouses. Thanks to wear-free drive technology, our smallest and light-weight gas ring blowers are equipped to handle even the toughest of jobs. Whether operated as vacuum pumps or compressors, they provide a minimum of 20,000 maintenance-free operating hours.

### Reliable even under the harshest conditions

These compact, encapsulated machines are a match for even the harshest environmental conditions. If problems occur upstream, they are protected against damage by integrated intelligent blocked-rotor and overload protection. G\_100 gas ring vacuum pumps and compressors can be operated in any axial orientation and are easy and economical to install and connect.



### Advantages at a glance

- Maximum power in the smallest spaces
- Long service life
- Maintenance-free operation
- Extremely quiet and vibration-free
- Installable in any axial orientation
- Usable worldwide, available ex warehouse, UL- and CSA-certified 
- Excellent control, continuously adjustable from 0 – 100%
- Blocked-rotor protection

### Main applications

- Packaging industry
- Medical technology
- Fuel cell technology
- Pneumatic conveying systems
- Printing and paper processing industry
- General mechanical engineering
- ... and many more

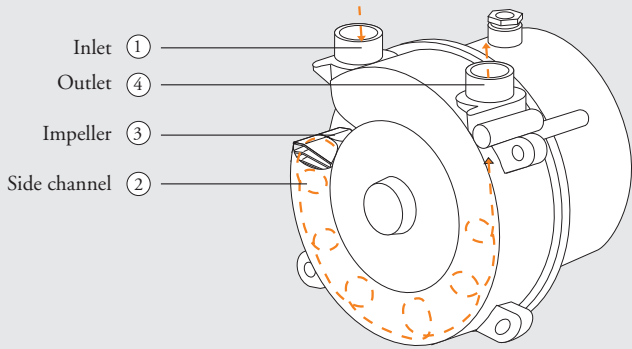
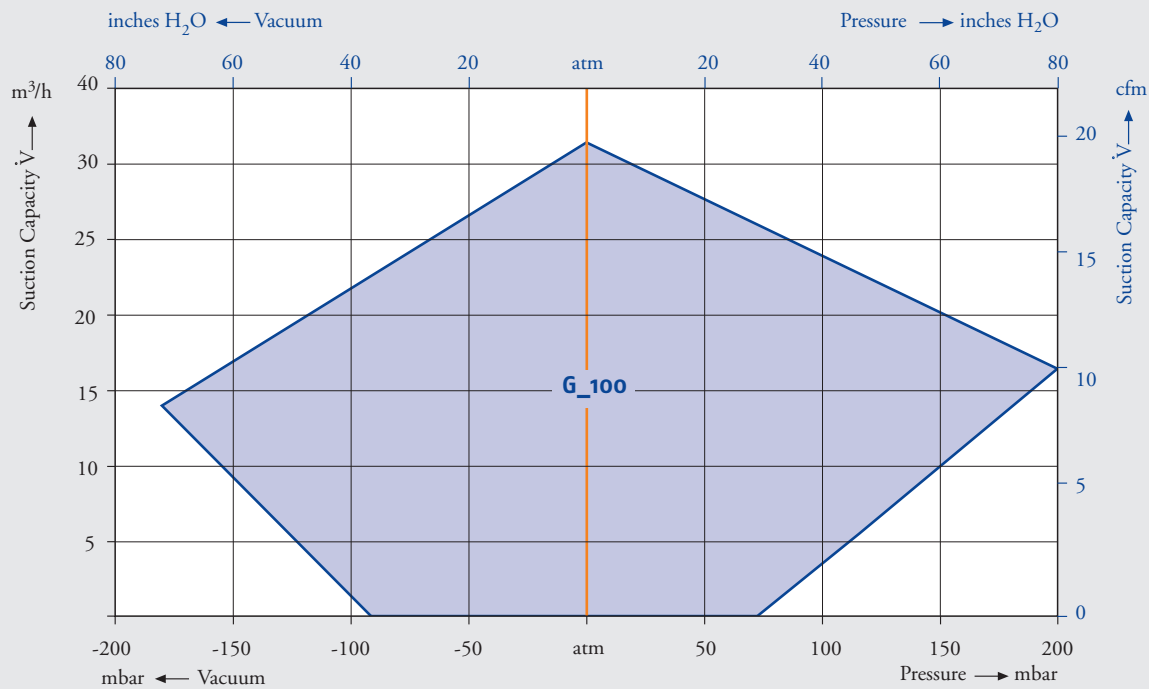

### Functional diagram

The gas is taken in through the inlet ①. As it enters the side channel ②, the rotating impeller ③ imparts velocity to the gas in the direction of rotation. Centrifugal force in the impeller blades accelerates the gas outward and the pressure increases. Every rotation adds kinetic energy. As a result of radial acceleration, pressure continues to increase along the side channel. The side channel narrows at the rotor, sweeping the gas off the impeller blades and discharging it through the outlet ④ where it exits the pump.

### Extremely quiet

The low noise emission of G\_100 machines meets the strict requirements of the most diverse industries – while also accommodating the subjective human sensitivity to noise. These devices are mainly used in medical technology and precision engineering applications. Despite their small size, they are so robust and durable that they are also used in other industries and applications.

### For worldwide use – ex stock

G\_100 vacuum pumps and compressors can be operated anywhere in the world. They conform to international standards, are UL- and CSA-certified and available ex stock.

### Environmentally friendly and inexpensive to operate

Our production process is certified to DIN EN ISO 14001. To conserve resources throughout their service life, G\_100 pumps and compressors operate without auxiliary materials and are extremely efficient, not only preserving the environment but also reducing your costs.

### Global quality management

Certified to DIN EN ISO 9001:2000, nash\_elmo always puts quality and customer satisfaction first. From the initial design phase through development, production, order processing, logistics and customer support, we always give you the best.

**We also design and develop solutions tailored to your individual needs. Let us know.**

**nash\_elmo Industries**  
 info@nash-elmo.com  
 www.nash-elmo.com

**Corporate Headquarters**  
**Trumbull, CT USA**  
 9 Trefoil Drive  
 Trumbull, CT  
 06611-1330  
 Tel.: +1 800 553 6274

**European Headquarters**  
**Nuremberg Germany**  
 Katzwanger Straße 150  
 D-90461 Nürnberg  
 Tel.: +49 911 1454 0

Order-Nr. VNE: **B-PB006-A2-AM**  
 Dispo 27801/SEK 4256  
 Printed in Germany  
 215900/36148 4.0/09-2003  
 © 2003 All Rights Reserved